

CIPPO CONFINE

Realizzato in cemento vibrocompresso.

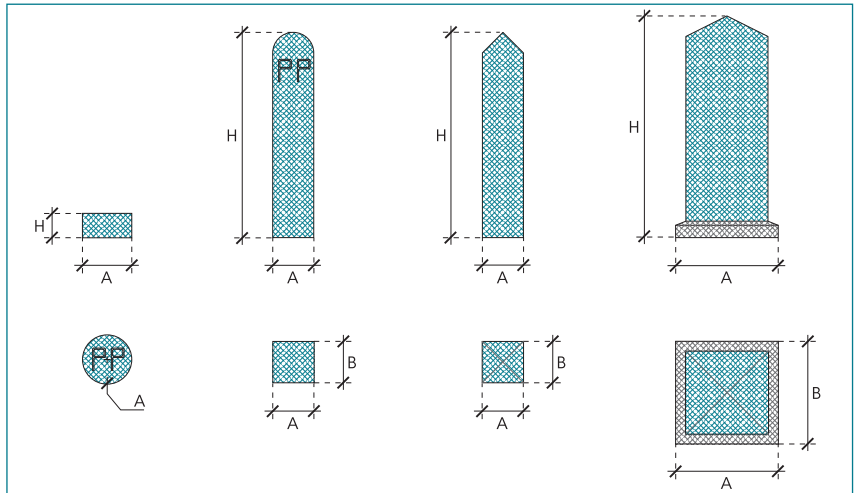
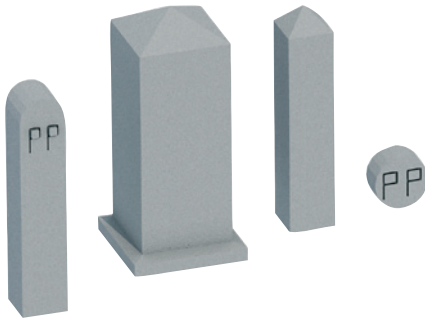

CODICE ARTICOLO	DIMENSIONI (cm) A x B	ALTEZZA (cm) H	CARATTERISTICHE	NOTE	VOLUME DI CARICO (m ³)	PESO (Kg)	PREZZO € /cad.
PCP5010	10 x 10	50			0,005	10	
PCP5020	20 x 20	50			0,020	40	
PPRIV	Ø 12	6	Cemento bianco		0,001	1,5	

Arredo urbano

PLINTO PER PIANTANE

Realizzato in cemento vibrocompresso.

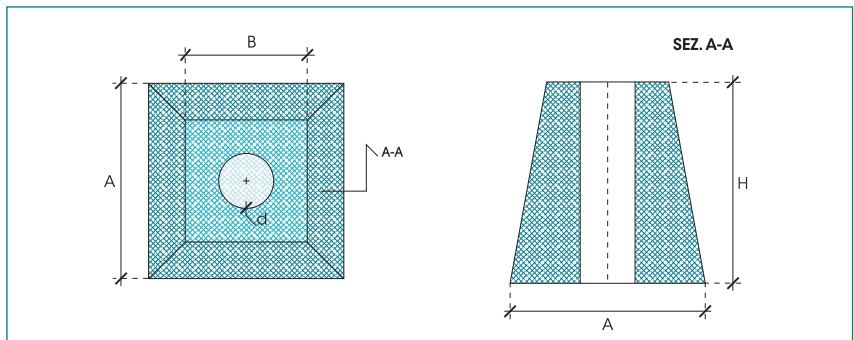
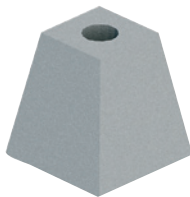

CODICE ARTICOLO	DIMENSIONI (cm) A x B	ALTEZZA (cm) H	DIAMETRO FORO (cm) d	NOTE	VOLUME DI CARICO (m ³)	PESO (Kg)	PREZZO € /cad.
PLV35	30 x 20	34	8		0,02	48	

Arredo urbano

LASTRA IN CEMENTO PER PASSATOIE E VESPAI

Armata con rete, superficie striata.
Realizzata in cemento vibrocompresso.

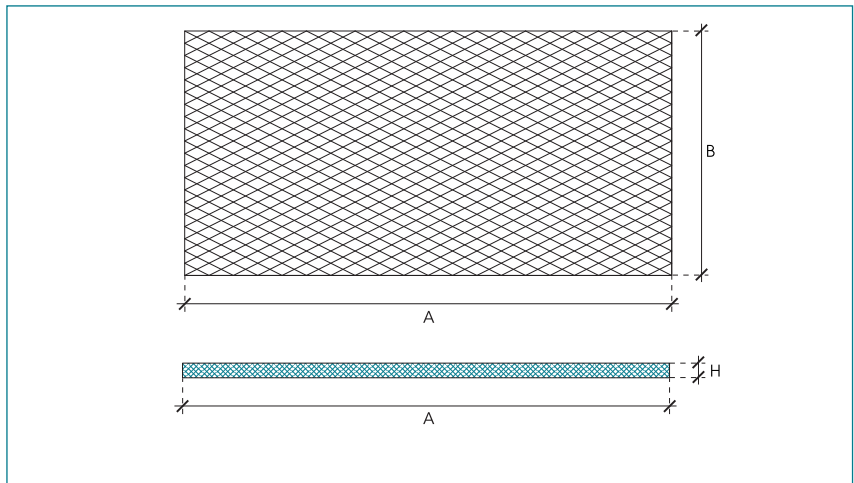
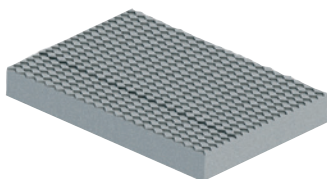

CODICE ARTICOLO	DIMENSIONI (cm) A x B	ALTEZZA (cm) H	PEZZI / IMBALLO	NOTE	VOLUME DI CARICO (m ³)	PESO (Kg)	PREZZO € /cad.
ZPNCEM50	100 x 50	3,5	20		0,015	43	